



SURVEYOR

Eco-Lite Edition **By Forest River**
Select



ADVANTAGES OF OWNING A SURVEYOR SELECT

Crafted Quality you demand at a price you can afford!

#1 ADVANTAGE | 6-SIDED ALUMINUM FRAMING

Our **6-Sided Aluminum Framing** around all openings ensures that windows, baggage & entrance doors, as well as appliances have the necessary backing needed for a water tight installation.

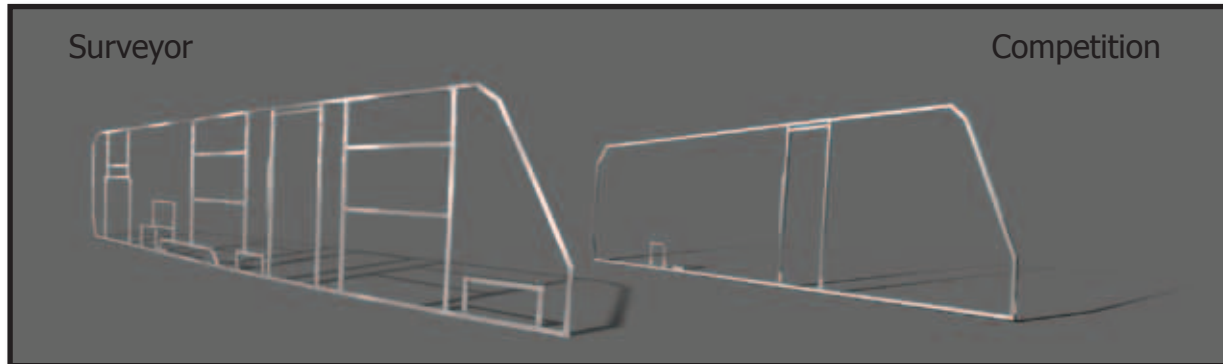

#2 ADVANTAGE | 2" EXTERIOR WALLS VS. 1.5" SIDEWALL

Fully laminated exterior walls are visibly stronger & more durable than the competition. We laminate each & every wall, floor, & roof, including the slide-out side walls.



SURVEYOR SELECT

2" Wall with (R-9) Block Foam Insulation

THE ADVANTAGE

Stronger with more Insulation



COMPETITOR

1.5" Wall with (R-7) Block Foam Insulation

#3 ADVANTAGE | TOWABILITY - Independent Torsion Axles vs. Leafspring

Rubber Torsion Independent Suspension Axles provides the **"Smoothest, Safest Tow"** on the market. Torsion Axles are the same as those used on Horse & Boat Trailers! Why? The precious cargo!



THE ADVANTAGE

Fully Independent Wheel Suspension

No Metal to Metal Contact & No Springs, Shackles, Hangers or U-Bolts to break our wear out

Lower Trailer Center of Gravity for Improved Stability

#4 ADVANTAGE | GREASE IS THE WORD...

We make it EASY with "EZ LUBE HUBS".

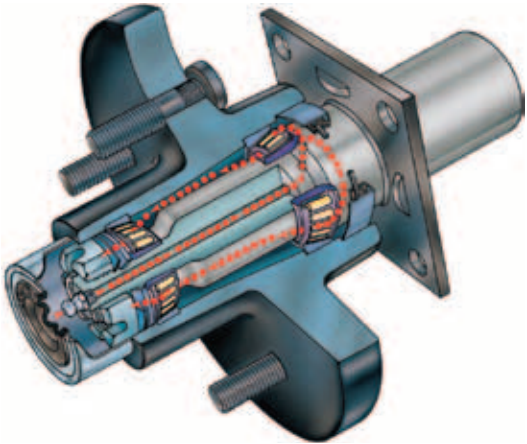

THE ADVANTAGE

Lubrication that's simple to maintain and completely submersible

Allows grease to easily flow to both outer and inner bearings for a complete repack

No disassembly required, just attach a grease gun at the end and inject the grease

#5 ADVANTAGE | RADIAL TIRES VS. BRAND-X

What do you want your tire to do for you? Hold Tire Pressure, Grip the Road in all conditions, Prevent Blow-outs. We use Radial Tires for your Peace of Mind, our competitors don't!

THE ADVANTAGE

Radial Tires are specifically designed to make trailer towing easier, more stable and more economical

Delivers dependable highway stability, positive traction and long lasting wear



#6 ADVANTAGE | EXTEND YOUR CAMPING TIME

Enclosed seamless aerodynamic design provides protection from road debris, center of gravity for towing ease & stability, reducing wind resistance for easier and more economical towing and longer use into cooler seasons.



THE ADVANTAGE

Seamless aerodynamic design

Protection from road debris

Keeps unwanted pests out

#7 ADVANTAGE | CONVENIENCE OF POWER

Setup is a Breeze with Surveyor Select's Push Button Electric Awning and Stabilizer Jacks.



#8 ADVANTAGE | SEAL TEST

Every unit is pressurized and soap tested at **every seam** and **every opening** to ensure a water tight seal.

THE ADVANTAGE

NO water leaks! We make sure of it!



#9 ADVANTAGE | CLEAN, LARGE PASS THROUGH STORAGE

Do you see any Water Lines? Heater Ducts? Electrical Wires? We made sure to keep this area clear of those things. Cargo can damage all these expensive non-warranty items if your storage pass thru is not as clean & as finished.

THE ADVANTAGE

Finished and sealed will keep your cargo clean and clear of leaks and becoming wet

Extra storage capacity

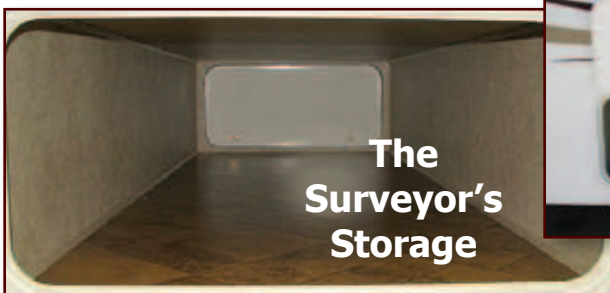

The Surveyor's Storage



Competition

Less storage & intruding pipes & wire



#10 ADVANTAGE | STRONGER & LONG LASTING

RV'ers ask for it so we listened. We utilized removable Power Cords. It is simply easier to use, easier to store, and replace if necessary. No need to do what our competitors expect you to do on their units, well you know... the old style "Cram" into a hole and hope for the best!

Surveyor



Competition



#11 ADVANTAGE | FEEL THE POWER

55 AMP Cheng™ Supreme Power Converter, a whole **22% more** than what our competitors use, 45 AMP converters!

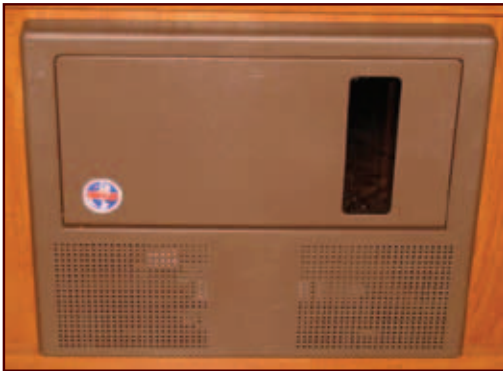

THE ADVANTAGE

You can have more things on in your unit!

In addition, LED Red Bulbs help identify which fuse is blown; no guessing or fumbling around!

#12 ADVANTAGE | WHAT'S IN YOUR WATER

You will appreciate the water filtration system that is **STANDARD** with each Surveyor Select. This compact unit filters water for the entire coach, eliminating those unwanted contaminants and odors.

We took the extra step to insuring safe drinking water for you and your family!



#13 ADVANTAGE | LP HARD ABS COVER

Two 30 pound tanks come standard-COVERED. Our competitors provide two 20 pound tanks with no cover or a cheap vinyl cover.



Surveyor

THE ADVANTAGE

Optimum Protection against the elements two 30 pound tanks

Easy to open, long lasting



Competition

#14 ADVANTAGE | OUTSIDE EXTRAS

Metal, NOT "Plastic" Door Latches, used on Surveyor Select Entry & "Storage Plus" Doors.



Surveyor Select Metal Latch



Outside Shower is **STANDARD** on all Surveyor Selects



Competition
Plastic Door Catches

#15 ADVANTAGE | SUPERIOR SLIDE-OUT

Slide-Outs: Constructed like rest of trailer, pinch rolled, insulated & aluminum framed.

SUPERIOR CONSTRUCTION!!!

THE ADVANTAGE

Fully laminated slide out box.

No hung walls here!



#16 ADVANTAGE | REAR LADDER & BUMPER



Roof Ladder Option available on most Surveyor Select models. Competition NOT an option!!! In addition Surveyor uses a 4" square bumper where most Competitors don't and inconveniently mount their spare tires under the front A-Frame.

THE ADVANTAGE

Makes easy to access and maintain the one piece rubber roof.

Bumper provides easy storing for the sewer hose and easy access to the spare tire.

#17 ADVANTAGE | THE GALLEY

Plenty of Space for the Gourmet... Surveyor Select provides Sink Covers, Stove Cover, Built-In Knife Block, High Rise Faucet and Counter Top Extensions (select models) for your convenience. What does Brand X offer?



THE ADVANTAGE

Added cutting & storage space

Safety & additional counter space

Keep sharp knives far away from children

Easy cleaning & filling of sink

Adding even more countertop space!

#18 ADVANTAGE | GALLEY EXTRAS

Message Command Center



Key Hooks

Message Cork Board

Hinged Door conceals switches for exterior light, slide-out(s), and power awnings.

Galley Drawer Bank

Top Drawer "Tip Out" Sponge Holder

Metal Drawer Guides on sides

Hard Wood Sides and Front Door insure long-life for years of use



#19 ADVANTAGE | TINTED SAFETY GLASS WINDOWS

Tinted Safety Glass Windows Standard on ALL Surveyor Selects Helps Reduce Heat and Prevents Damaging Rays from Fading your Interiors!!!



THE ADVANTAGE

Blocks Heat

Prevents Fading

#20 ADVANTAGE | OLD FAITHFUL

6-Gallon Gas/Electric DSI Super High Output Suburban® Water Heater, Uses Anode Rod to protect heating element and extend longer life of water heater



THE ADVANTAGE

Makes 16.2 Hot Water Gallons per hour, this is the same or more than any 10 or 12 Gallon Water Heater in the industry!

The competition uses Atwood water heater which makes half as many gallons per hour, only 7.4 hot water gallons, & does not have an Anode Rod!

#21 ADVANTAGE | DINING IN STYLE

Dinette Features

- Easy Access Doors (Select Models)
- Designer Camel-Back Seat Cushions (booths)
- E-Z Glide Dinette Tables (STD all models)
- Hinged Booth Seats allow for easy full access
- Reversible Seat Cushions with vinyl on backside for wet bathing suits

How does the Competition seat you?



#22 ADVANTAGE | SERTA® 60" X 80" DREAMSCAPE MATTRESS



Stretch out and sleep in the Forest River Exclusive Serta® Dreamscape Mattress.

THE ADVANTAGE

No "wrinkles", your sheets & bedspread now fit snugly
Taller people can enjoy RV'ing and get a good nights rest!
Higher Coil count for Superior Back Support
Serta® Patented foam for Added Comfort
Quilted top for Stability

#23 ADVANTAGE | REAL WOOD

Genesis® Endura Raised Hardwood Panel Cherry Glazed Doors come with a 10 Year Warranty and are complimented by "Easy Opening" Oiled Brass Hardware Handles.

THE ADVANTAGE

10 Year Warranty



#24 ADVANTAGE | ELEGANCE



In the Living Room you will find elegant features like:

Smoked Glass Door Fronts on slide-out overhead cabinets
Designer Privacy with styled Hard Valances & Side Lambrequins
Decorative Wall Border Edging

The competition does not use smoked glass cabinet doors, & often times have no lambrequins, or if they have them are very "soft" and won't last.

#25 ADVANTAGE | BEHIND CLOSED DOORS

What to **EXPECT** from Surveyor Select but **NOT** the competition:

Adjustable Pantry Shelves - "Oversized Boxes" - No Problem!



"Spring Loaded" Residential Style Hidden Hinges - Great Looking and Self Closing"

"Hard Wood" Cabinet Stiles - No Press Board or Staples Here, Surveyor Screws and Glues for Superior Cabinet Construction!



#26 ADVANTAGE | STRUTTING OUR STUFF



100 lb. Gas Struts Under Queen Bed

THE ADVANTAGE

Makes it much easier to lift the bed and access storage below... Competition either doesn't have any or only uses 40lb. gas struts which doesn't hold up the bed!

Surveyor makes it Easy!

#27 ADVANTAGE | COMFORT

"Air Mattress Hide-A-Bed" Sofa mixes beauty & function with extreme comfort for sleeping. Easy set-up comes with air pump for quick inflation or deflation.



#28 ADVANTAGE | HAND CRAFTED



Surveyor

All comforts of your home bath built in! Hand Crafted Medicine Cabinet with raised interior shelves help hold in bath items while traveling.

The competition... well we could have gone cheaper like the other guys, but that wouldn't make us better!



Competition

#29 ADVANTAGE | FANTASTIC!

Making your living space more comfortable, Surveyor Select provides you with the industry leading 3-Speed, 12", 10-Blade Fantastic Fan.

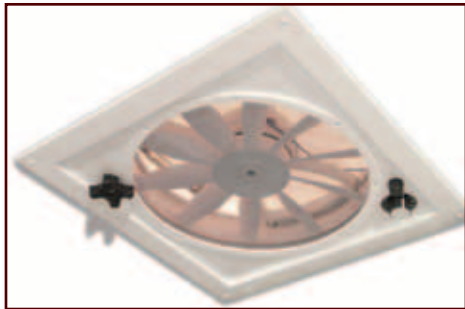

Surveyor Select

The competitor... well most use the "1-speed, 6", 4-blade" with red button, and only a One-year warranty!

THE ADVANTAGE

Provides a comfortable living space
"Lifetime of the trailer" Warranty!



Competition

#30 ADVANTAGE | PLENTY OF ROOM

There is plenty of room in the tub with surround. Surveyor Select gives you built in shelving to hold your soap, shampoo, wash cloth, razor. With our competitors you will be holding everything in your hands with no place to put your showering necessities!



Thetford® Foot Flush Toilet makes it easy and sanitary to use the commode!



#31 ADVANTAGE | HOT & COLD



Ducted Air Conditioning Standard 25' and above Travel Trailers. A/C Vents can rotate 360° as well as closed by the touch of a finger!

Surveyor's High Efficiency 30,000 BTU Furnace with Residential in Floor Ducted Heating insures comfort on those chilly evenings!!! (STD. 25' and longer)



#32 ADVANTAGE | IN TUNE

Standard 200 Watt AM/FM/CD/DVD Stereo with AUX Plug In for Ipod Adaptor Cord, USB and SD Card Slots, "Let the Good Times Roll".

Optional Outside Speakers take the music or sports programming under your awning area!



#33 ADVANTAGE | PEACE OF MIND

Your not forgotten about after the sale. **FREE** for 1 year, Coach-Net® 24/7 technical and emergency support anywhere in North America!



THE ADVANTAGE

Service Assistance, speak with a Certified RVIA Technician for advice or where to seek service.

Emergency Roadside, includes Free jump-starts, tire changes, fuel delivery and lock out service

\$2,000 Trip Interruption Reimbursement if you're stuck. No need to miss out on your Dream Vacation!



Select

33 ADVANTAGE COMPARISONS

1. 6-SIDED ALUMINUM FRAMING
2. 2" EXTERIOR WALLS VS. 1.5" SIDEWALL
3. TOWABILITY - INDEPENDENT TORSION AXLES VS. LEAFSPRINGS
4. GREASE IS THE WORD... EZ LUBE HUBS
5. RADIAL TIRES VS. BRAND X
6. EXTEND YOUR CAMPING TIME
7. CONVENIENCE OF POWER
8. SEAL TEST | NO WATER LEAKS!
9. CLEAN, LARGE PASS THROUGH STORAGE
10. STRONGER AND LONG LASTING | POWER CORDS
11. CHENG™ POWER CONVERTER
12. WHAT'S IN YOUR WATER | FILTRATION
13. LP HARD ABS COVER
14. OUTSIDE EXTRAS
15. SUPERIOR SLIDE-OUT
16. REAR LADDER & BUMPER
17. THE GALLEY | ADDED STORAGE & COUNTERSPACE
18. GALLEY EXTRAS | MESSAGE COMMAND CENTER & GALLEY DRAWER BANK
19. TINTED SAFETY GLASS WINDOWS
20. OLD FAITHFUL | WATER HEATER 16.2 HOT WATER GALLONS PER HOUR
21. DINING IN STYLE
22. SERTA® 60" X 80" DREAMSCAPE MATTRESS
23. REAL HARDWOOD
24. ELEGANCE | SMOKED GLASS, DESIGNER VALANCES
25. BEHIND CLOSED DOORS | PANTRY
26. STRUTTING OUR STUFF | 100 LBS. GAS STRUTS
27. COMFORT | AIR MATTRESS HIDE-A-BED
28. HAND CRAFTED | BUILT IN MEDICINE CABINET
29. FANTASTIC FAN | LIFETIME OF TRAILER WARRANTY
30. PLENTY OF ROOM | ABS TUB SURROUND
31. HOT & COLD | DUCTED A/C VENT, IN-FLOOR HEAT DUCT
32. IN TUNE | AM/FM/CD/DVD STEREO
33. PEACE OF MIND | 1 YEAR FREE COACH-NET 24/7 SUPPORT

As Surveyor constantly strives to improve our products, all specifications listed, optional items & general photos are subject to change without notice or obligation.

112310/R2